

FIREMATE SERIES - FIRE FIGHTING PUMPS

The "FIREMATE" Series are high pressure multipurpose pumps. These HONDA powered, compact and lightweight units have endless application uses. The SERH-50F features a 3-way discharge flange, mounted inside a lightweight and rugged rollframe with anti-vibration mounts. There isn't a better built fire pump.

APPLICATIONS:

- Fire-Fighting
- Water Transfer
- Site Pumping
- Irrigation
- Sprinklers
- Agriculture

ADVANTAGES

- Rugged and lightweight.
- Hose fittings and strainer.
- Roll cage for ease of handling & transport.
- Genuine HONDA engine.
- Japanese quality.

SUCTION PERFORMANCE

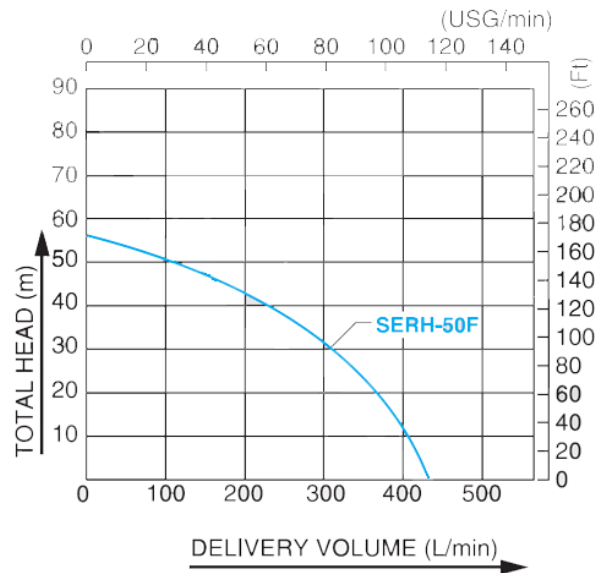
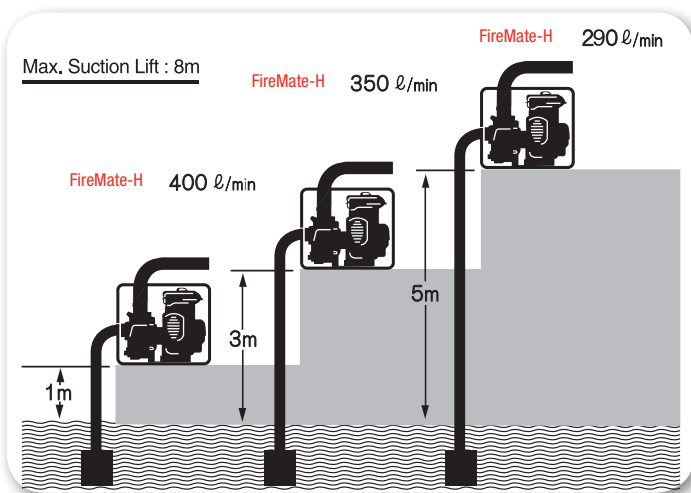

PERFORMANCE TABLE

PUMP					ENGINE					
MODEL	MAX. FLOW	MAX. HEAD	MAX. SUCTION LIFT	SUCTION / DISCHARGE CONNECTION	TYPE	MODEL	RATED OUTPUT	FUEL TANK CAPACITY	CONT. RUN TIME	STARTER METHOD
SERH-50F	440 L/min	57m	8m	2" BSP (50mm) 2 x 1" BSP (25mm)	4 Stroke	Honda GX160	2.9kW / 3600rpm	3.1 L	2 Hrs	Recoil